

MILK COOLING TANK WITH ICE WATER COOLING OM/IB 600 - 2300 L



Construction

- Construction completely made in stainless steel 18/10 – AISI 304
- Insulated with polyurethane for an excellent insulation and extra strength of the tank
- Evaporator coils in the ice bank are made of seamless copper tubing.
- Space-saving, ergonomic design
- The U-shape allows easy but thorough cleaning with a minimum of effort
- Cover mounted on pneumatic springs, allowing easy and safe opening and closing of the tank
- Efficient agitator mixes even small quantities of milk
- Standard outlet Ø 50 mm with butterfly valve

Cooling

- Fast cooling without any risk on freezing of even the smallest quantities of milk
- Time clock for use of night rate
- PCV2-2 control unit ensures a qualitative milk cooling
- Digital temperature indication with large LED-display

Important options

- Set instant cooling
- Calibration
- Automatic cleaning



DIMENSIONS OM/IB

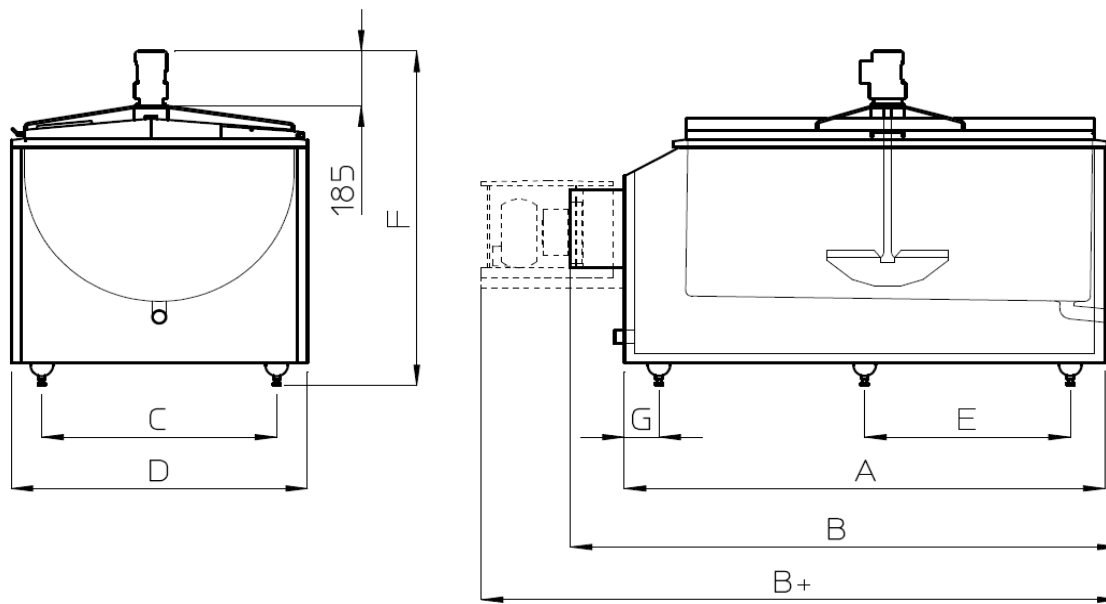

Model	Max. vol.	A	B	B+	C	D	E	F	G	Agitator	Legs	Weight
OMIB	litres	mm	mm	mm	mm	mm	mm	mm	mm	#	#	kg
600	635	1 382	1 632	1 972	870	1 080	1 124	1 250 - 1 300	129	1	4	192
800	843	1 781	2 032	2 372	870	1 080	1 524	1 534 - 1 579	129	1	4	242
1000	1054	2 132	2 382	2 722	870	1 080	1 874	1 871 - 1 916	129	1	4	270
1200	1264	2 482	2 732	3 072	870	1 080	1 112	1 887 - 1 932	129	1	6	300
1500	1697	2 152	2 402	-	1 238	1 461	965	1 869 - 1 914	111	1	6	327
1800	1930	2 532	2 782	-	1 238	1 461	1 155	1 876 - 1 921	111	1	6	395
2300	2385	2 882	3 132	-	1 238	1 461	1 330	1 883 - 1 928	111	1	6	490

Available in 2 & 4 milkings

B+ : with incorporated cooling unit (only possible for cooling units up to and including Eco-cool 2)

Fullwood Packo nv

Torhoutsesteenweg 154 - 8210 Zedelgem - Belgium

T +32 50 25 06 10 - E cooling@fullwoodpacko.com

www.packocooling.com